

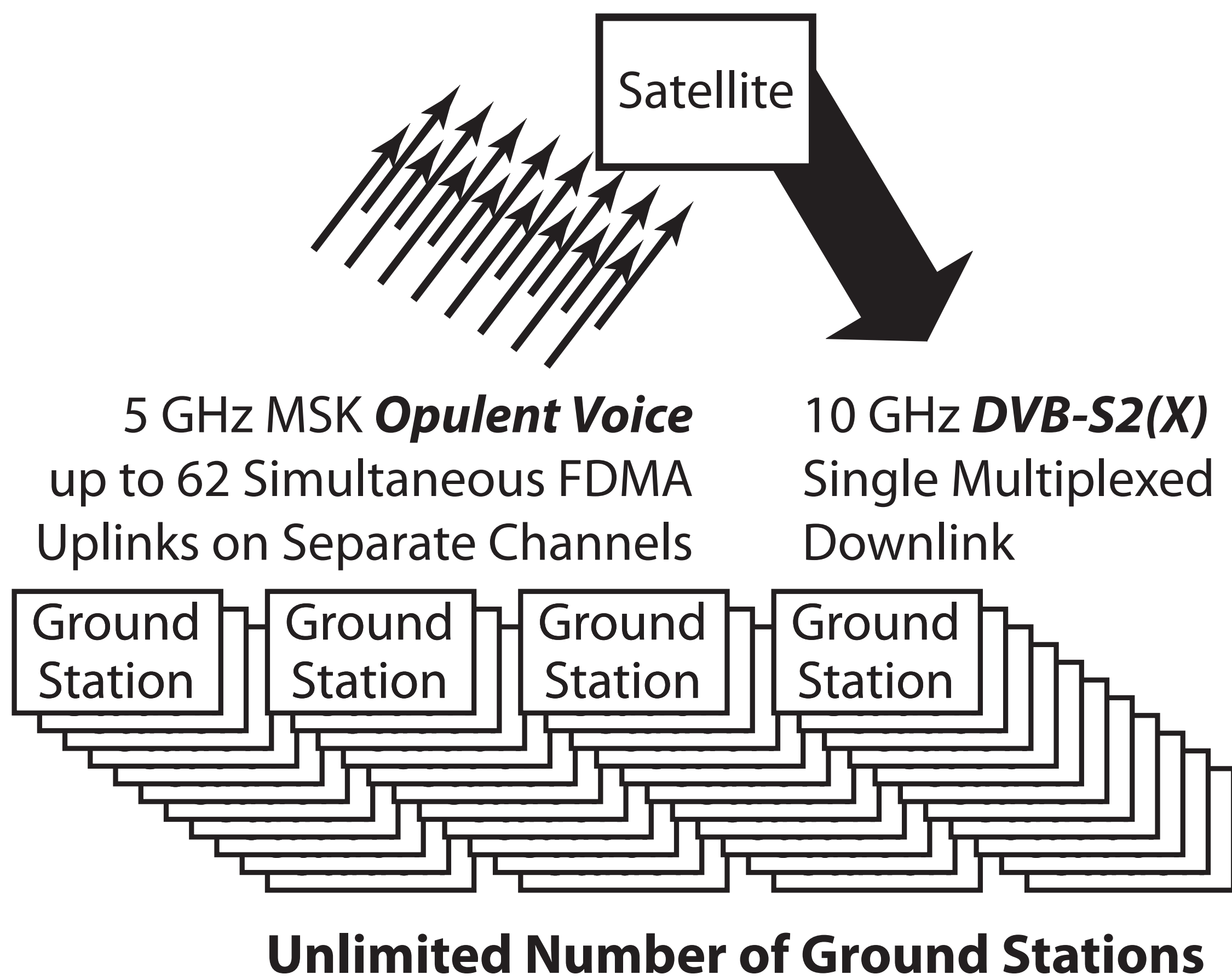

System Overview

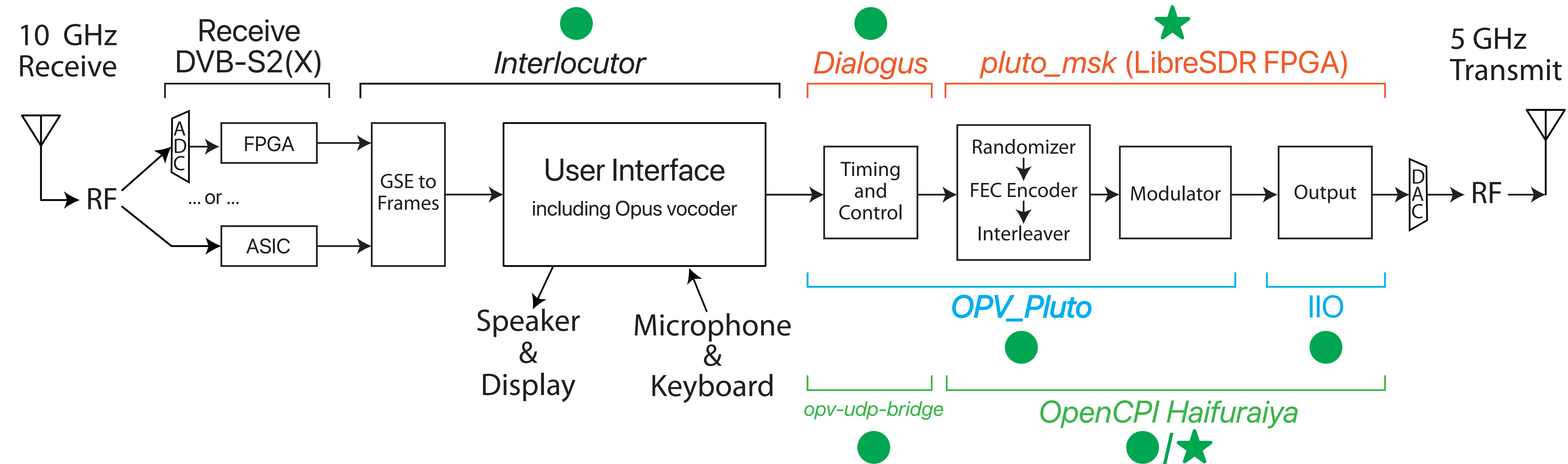

Three Ground Station Implementations (so far)



★ = VHDL FPGA module is implemented and largely working.

● = Software module is implemented and largely working.

Open Research Institute (ORI) is a non-profit research and development organization which provides all of its work to the general public under the principles of Open Source and Open Access to Research.

100% Open Source: Everything in these designs is released under recognized open source licenses. Hardware is compliant with the Open Source Hardware Definition and licensed under the CERN Open Hardware License Version 2 Permissive. Software is licensed under the GNU General Public License 3.0, or compatible. Both are published on public **git** repositories, early and often.

Satellite Transponder Architectures

One of two separate but similar implementations shown.

Everything in the Haifuraiya transponder between the receive low noise amplifier and the transmit filters and power amplifier runs on a subset of the Xilinx ZCU102 MPSoC development board (mainly the Zynq UltraScale+ device and its direct support circuits) plus the Analog Devices ADRV9002 or AD9361 RF transceiver eval board.

1 Uplink Receiver
10 MHz wide
10M I/Q samples/sec

64 Uplink Channels
156 kHz wide
625k samples/sec

8 (TBD) channel processors,
each multiplexing to handle
8 (TBD) uplink channels

Move data
to the CPU

Create downlink data stream from uplink data and telemetry, etc.

